

**TTP 243 Pro/ 243E Pro/ 342 Pro**

**THERMAL TRANSFER / DIRECT THERMAL  
BAR CODE PRINTER**

**Service Manual**

## Table of Contents

<b>1. FUNDAMENTALS ABOUT THE SYSTEM</b> .....	<b>1</b>
1.1 Features of the TTP-243 Series .....	1
1.2 Model Naming Syntax.....	1
1.3 Overview .....	2
1.3.1 Front View.....	2
1.3.2 Rear View .....	3
1.4 Basic Specifications.....	4
1.5 Effective Print Area.....	6
1.6 Available Bar Codes .....	6
1.7 Various Sensors .....	7
<b>2. SUPPLY SPECIFICATIONS</b> .....	<b>9</b>
2.1 Types of Paper .....	9
2.2 Specifications .....	9
2.3 Ribbon Sizes and Shapes .....	11
<b>3. ELECTRONICS</b> .....	<b>12</b>
3.1 Summary of Board Connectors .....	12
3.2 Pin Configuration.....	14
<b>4. MECHANISM</b> .....	<b>16</b>
4.1 Mainboard Replacement.....	16
4.2 Cutter Installation (Option / Not available for TTP-243E Pro model).....	20
4.3 Print Head Replacement .....	21
4.4 DC Motor Replacement .....	23
4.5 Ribbon Rewind Spindle Encoder Replacement .....	24
4.6 Felt Fabric Replacement .....	25
4.7 Stepping Motor Replacement .....	27
4.8 Black Mark Sensor / Gap Sensor (Receiver) Replacement .....	28
4.9 Ribbon Sensor (Receiver) Replacement.....	29
4.10 Ribbon Sensor (Transmitter) / Gap Sensor (Transmitter) Replacement .....	31

---

4.11 Platen Replacement .....	32
<b>5. TROUBLE SHOOTING.....</b>	<b>35</b>
5.1 Trouble Shooting .....	35
5.2 Calibrate the Gap Register .....	36
5.3 Self-test.....	36
5.4 Ram Clear .....	36
5.5 Diagnosis Operation Procedure.....	36
5.6 Testing Sensors .....	37
5.7 Cleaning the Print Head .....	38

## 1. FUNDAMENTALS ABOUT THE SYSTEM

### 1.1 Features of the TTP-243 Series

1. This bar code printer prints bar codes, characters, logos, on various types of labels and tickets by direct thermal or thermal transfer printing.
2. This printer adopts a "BASIC-like" high level programming language to help users programme the desired label forms with ease.
3. This bar code printer can be connected to a personal computer or an optional LCD keyboard to execute the programs downloaded in the printer's memory. The printer is equipped with the following standard devices: black mark sensor, peel off module and real time clock.
4. This bar code printer provides a selection of optional features, including cutter module, memory module, portable LCD keyboard, etc.
5. The user friendly labeling software package is bundled with printer.

### 1.2 Model Naming Syntax

T T P - 2 4 3  
(1) (2) (3) (4)

(1) Print method:

TTP – Thermal Transfer Printing

TDP – Thermal Direct Printing

(2) Resolution of print head (DPI)

(3) Maximum print width (Inch)

(4) Maximum print speed (Inch/Sec)

## 1.3 Overview

### 1.3.1 Front View

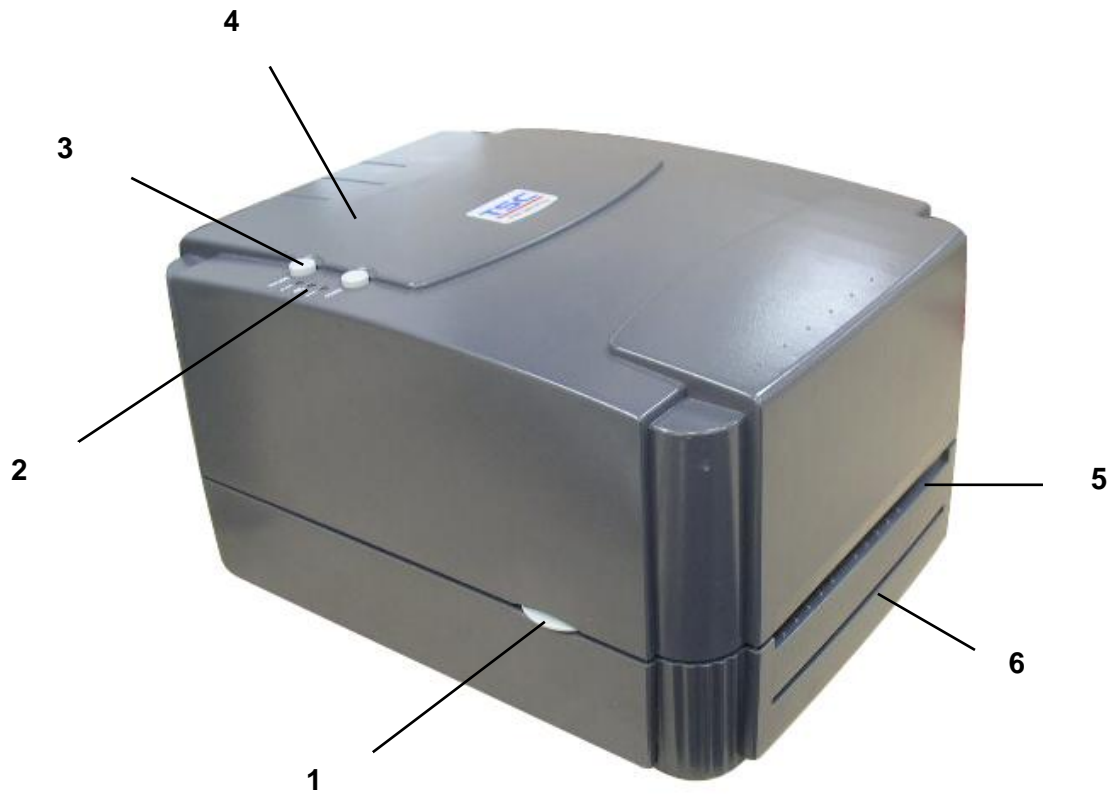

1. Cover Release Button
2. PWR., ON-LINE and ERR. Indicators
3. PAUSE Button
4. FEED Button
5. Label Dispense Opening
6. Liner Opening (For use with peel-off function/ Not available for 243E series printer)

## 1.3.2 Rear View

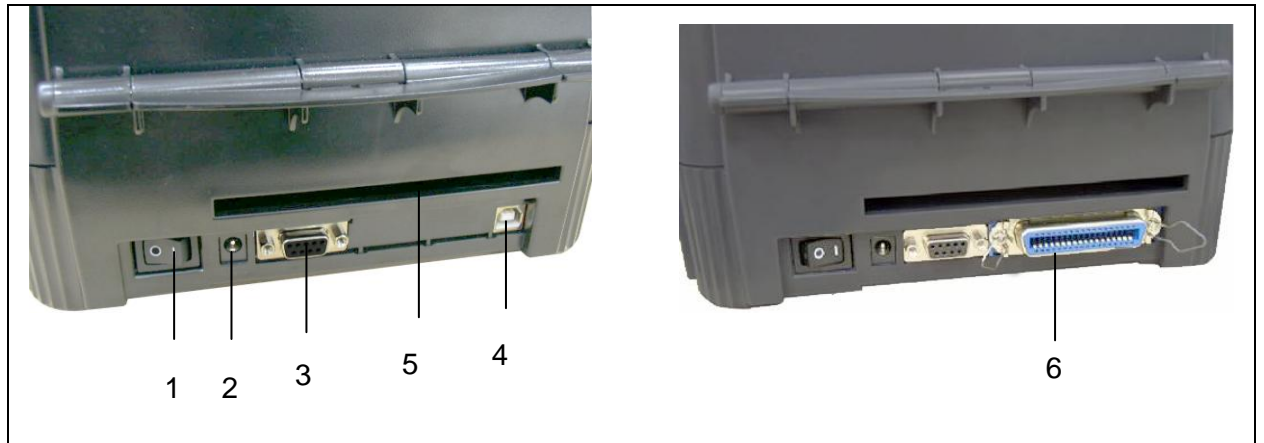

1. Power On/Off Switch
2. Power Supply DC Jacket
3. RS-232C Interface Connector
4. USB Interface Connector
5. Label Insert Opening (For use with external media)
6. Centronics Interface Connector (Factory option)

## 1.4 Basic Specifications

- Thermal transfer and direct thermal printing
- High dot density printing (243 Pro series: 203 dots/inch, 342 Pro series: 300 dots/inch)
- Selectable print speeds at 1.5", 2.0" or 3.0" per second (243 Pro series: 1.5, 2 and 3 ips / 342 Pro series: 1, 1.5 and 2 ips)
- Supports RS-232 serial and USB interface (Factory option for RS-232 and Centronics interface)
- Maximum media width up to 4.49" (114 mm)
- Adjustable label edge guide
- International character sets
- Print area : TTP-243 Pro/243E Pro : 4.09" W x 90" L ; TTP-342 Pro : 4.09"W x 40"L (without any file downloaded in the printer memory)
- User selectable bar code ratios and heights
- Prints on labels or tickets
- Equipped with black mark sensor
- Equipped with Real Time Clock (Not available for TTP-243E Pro)
- Comes with self-peeling function (Not available for TTP-243E Pro)
- Buzzer provided to warn of possible errors (Not available for TTP-243E Pro)
- Label stock and thermal transfer ribbon are easy to install
- Internal label print counter
- Self test and hex dump mode
- Downloadable fonts from label design software

### Electronics/Communication Specifications

- Electrical

DC Motor: DC24V

Memory:

—SDRAM: 8 Mb

—Flash: 4 Mb

Adapter 100~240VAC±10%, 50~60Hz

Regulations: FCC Class A, CE Class A, C-Tick Class A, TÜV/Safety, CCC

- Communications Interface:

Serial port: RS-232C (DB-9) at 2400, 4800, 9600 or 19200 baud rate

—Word Length: 7 or 8 data bits, 1 or 2 stop bits, selectable parity

—Handshaking: XON/XOFF and DSR/DTR

Parallel port: Standard parallel interface

Input Buffer: 64KB

- RS-232 Interface Pin Configuration:

# TTP-243 Pro/ 243E Pro/ 342 Pro Bar Code Printer

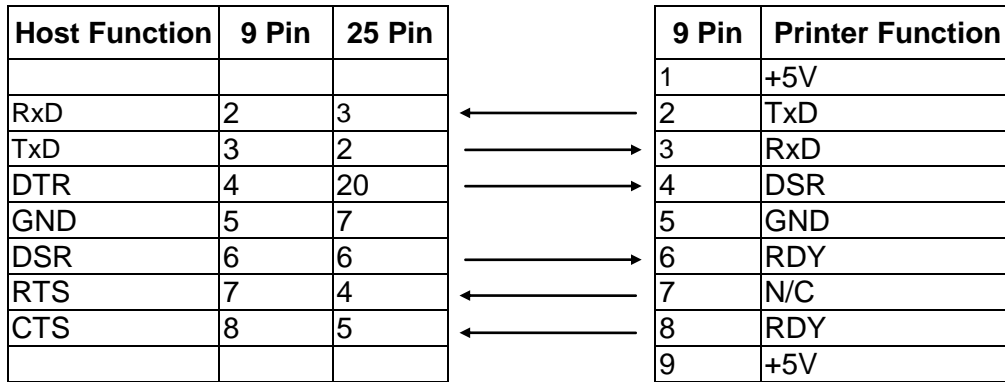



### 1.5 Effective Print Area

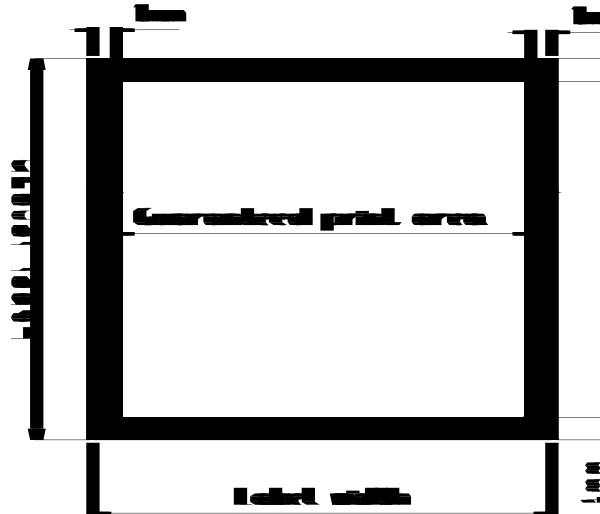

Label/Ticket Length	12mm~2286mm
Effective Print Length	10mm~2284mm
Label/Ticket Width	25mm~103mm
Effective Print Width	23mm~101mm
No Print Area	1mm

### 1.6 Available Bar Codes

#### 1D bar code

Code 39, Code 93, Code128UCC, Code128 subsets A.B.C, Codabar, Interleave 2 of 5, EAN-8, EAN-13, EAN-128, UPC-A, UPC-E, EAN and UPC 2(5) digits add-on, MSI, PLESSEY, POSTNET, RSS-Stacked, RSS14, Code 11, China Post

#### 2D bar code

PDF-417, Maxicode, DataMatrix, QR code, Aztec

## 1.7 Various Sensors

### Feed Gap Sensor

The feed gap sensor detects a label gap to locate the starting print position of the next label. The sensor is mounted 4 mm off the center line of the main mechanism.

In case of Label

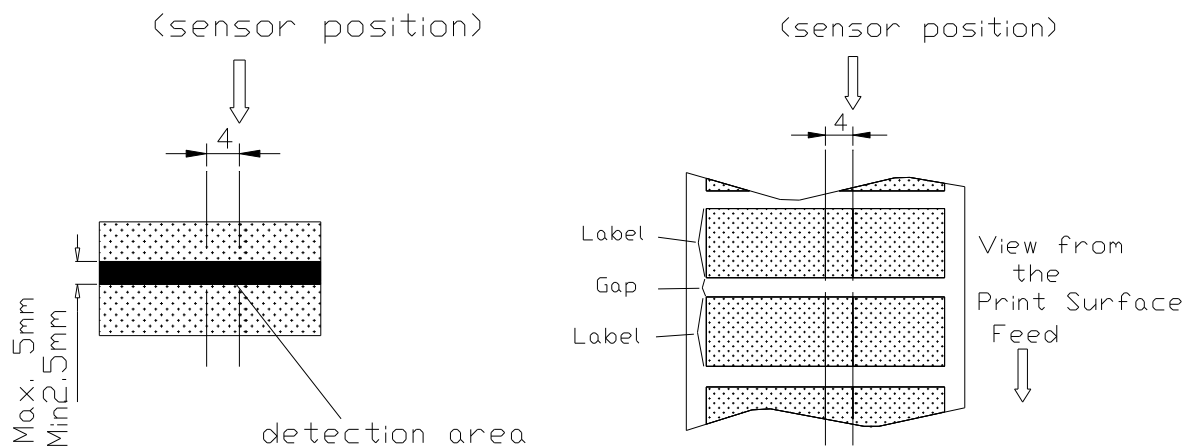

### Black Mark Sensor

The black mark sensor locates the position of label by emitting infrared rays onto the black mark at the back of the ticket. The sensor is mounted 5.75 mm off the center line of the ticket roll width on the mechanism.

## In case of Ticket

The default sensor position is (1) as shown on the figure below. To change to the (2) position, the customer should notify the manufacturer in advance. There can be only one position for the sensor. Once the sensor position is agreed upon, it can not be changed afterwards.

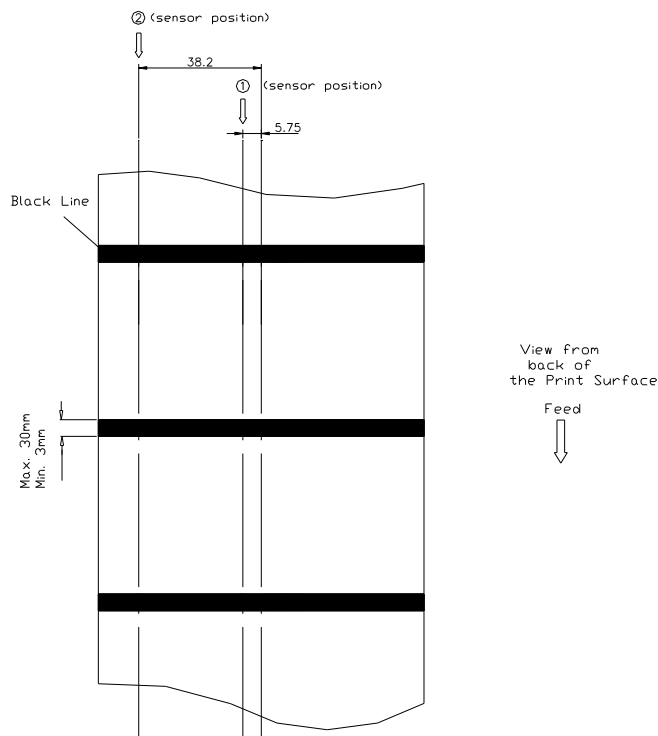

## Ribbon End Sensor

The sensor detects the end portion of the ribbon. The ribbon end must be transparent.

## Label End Sensor

The sensor detects the end portion of the label.

## Peel off Sensor

The sensor detects the backing paper of a label.

## Ribbon encoder

The encoder is used to detect if the ribbon is broken.

## 2. SUPPLY SPECIFICATIONS

### 2.1 Types of Paper

Two types of media are available for TTP-243: label and ticket.

In TTP-243, there are two types of sensors for paper: gap sensor and black mark sensor.

Label and ticket can be further classified into direct thermal type or thermal transfer type.

### 2.2 Specifications

Items	Label
Paper Width	Max. 114mm
	Min. 25mm
Length (Pitch)	12~2286mm
Paper Thickness	0.20 mm
Paper Weight	Max 240 g/m <sup>2</sup>
Max. Roll Diameter (1" core)	Inner roll diameter. Max 4.3" (110mm)
	External roll diameter. Max 8.4" (214mm)
Roll Up Method	Print surface wound outside as standard
Paper Core ID.	φ25.7±0.3mm

**Note:**

- (1). The width and thickness quoted above are said of the label plus its backing paper.
- (2). Likewise, the approval of label entails that of its backing paper.
- (3). In the peel off mode, the minimum pitch is 35mm.
- (4). In the cutter mode, it is required the paper be wound outside. Otherwise, paper jam tends to result.
- (5). In the cutter mode, the paper thickness is 0.2 mm at maximum, and the paper weight is 100 g/m<sup>2</sup> at maximum.
- (6). Paper shape is as shown on next page.
- (7). Tag is 0.2mm in thickness, and is less than 100g/m<sup>2</sup> in weight.

# TTP-243 Pro/ 243E Pro/ 342 Pro Bar Code Printer

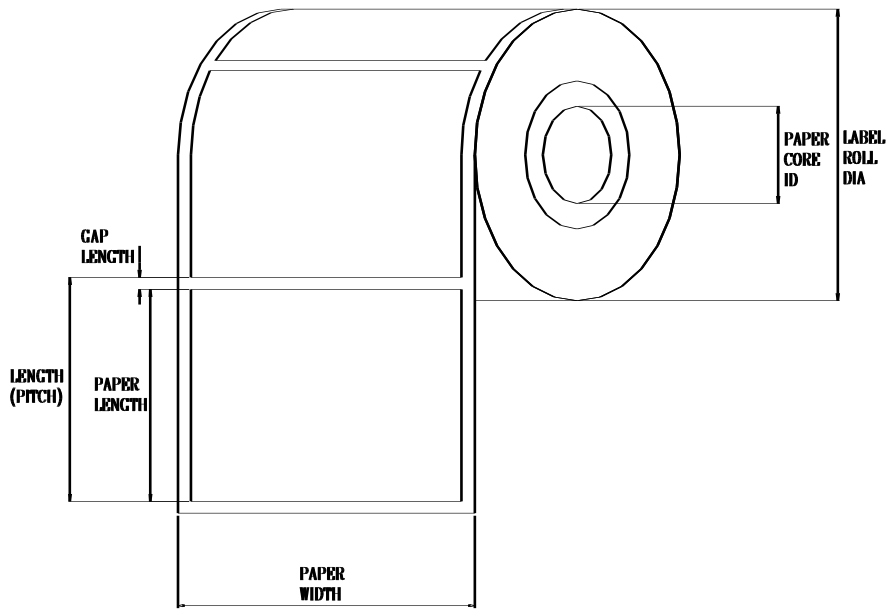

### 2.3 Ribbon Sizes and Shapes

Item	Specifications
Ribbon shape	Spool type
Ribbon width	Max. 110mm
	Min. 40mm
Ribbon winding width	Max. 110mm
	Min. 40mm
Leading tape	Polyester film, 335±5mm long
End tape	Polyester film (transparent), 250±5mm long
Max. ribbon OD.	φ67mm
Winding method	Ink surface to be wound outside

**Note:** The maximum length of ribbon depends on its thickness and core outside diameter.

The formula below defines the correlation between ribbon roll length and ribbon core diameter.

$$L = \frac{(D^2 - d^2) \times \pi}{4t}, \text{ where}$$

- L = Ribbon length
- D = Max. roll diameter
- d = Ribbon core outside diameter
- t = Ribbon thickness

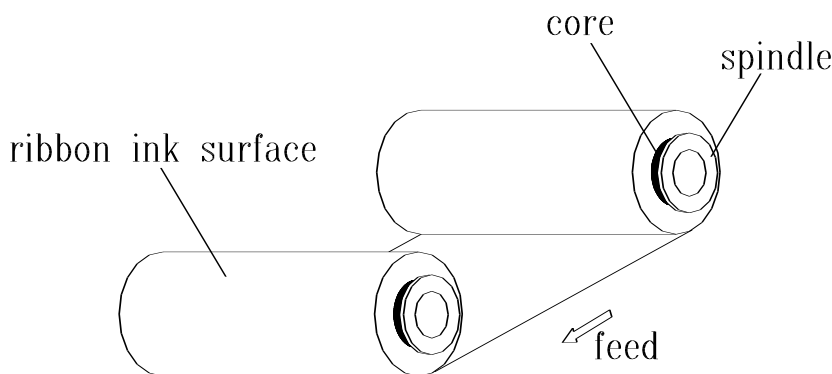
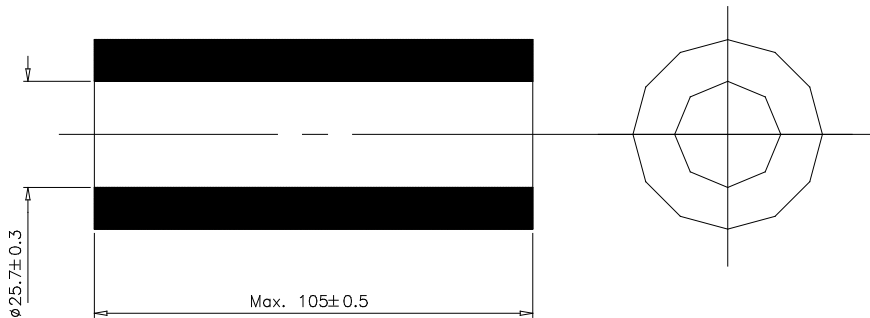

## 3. ELECTRONICS

### 3.1 Summary of Board Connectors

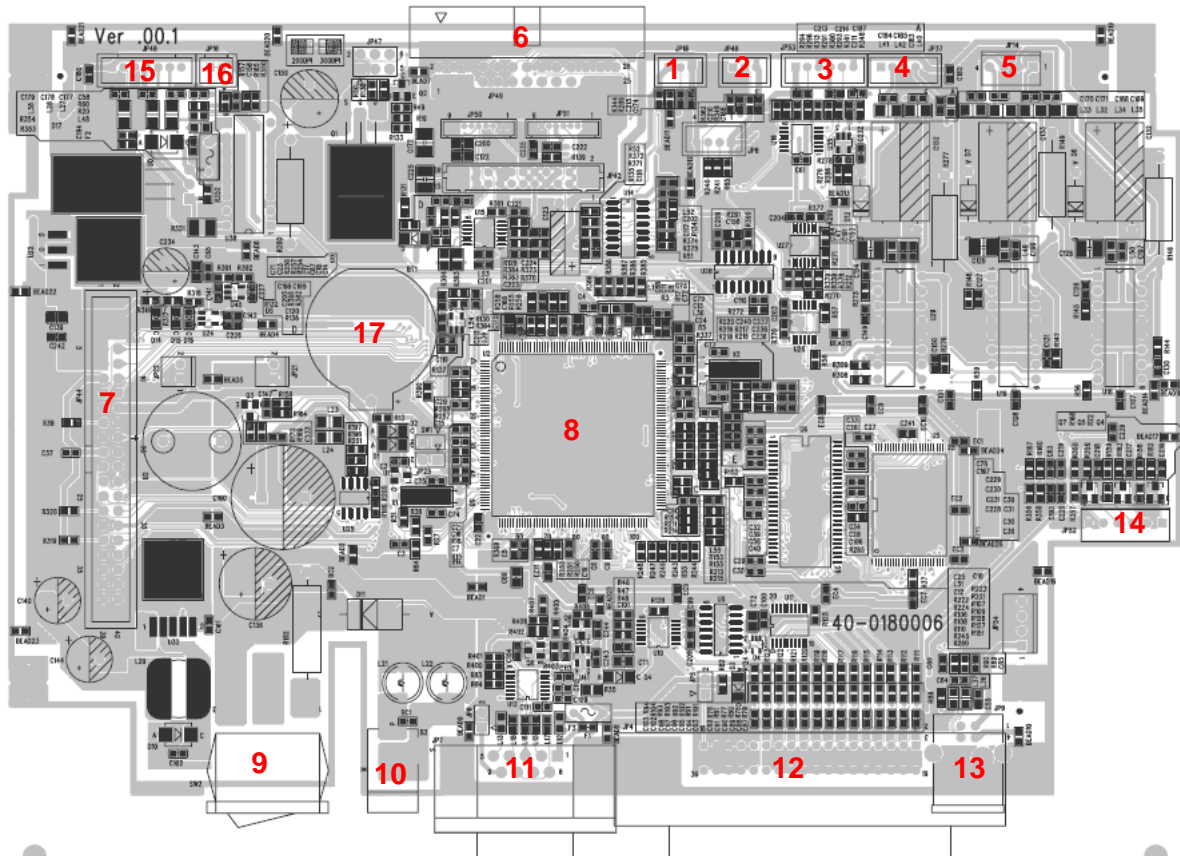

#### Main board



Connector	Description	Remark												
1	Ribbon sensor connector	JP18												
2	Black mark sensor connector	JP46												
	<table border="1"> <thead> <tr> <th>Pin</th> <th>Description</th> <th>Voltage</th> </tr> </thead> <tbody> <tr> <td>1</td> <td>Power</td> <td>5V</td> </tr> <tr> <td>2</td> <td>Black mark sensor receiver</td> <td>No paper or black mark : 3.1~3.2V Detect paper: 0~0.3V</td> </tr> <tr> <td>3</td> <td>GND</td> <td>0V</td> </tr> </tbody> </table>		Pin	Description	Voltage	1	Power	5V	2	Black mark sensor receiver	No paper or black mark : 3.1~3.2V Detect paper: 0~0.3V	3	GND	0V
	Pin	Description	Voltage											
	1	Power	5V											
2	Black mark sensor receiver	No paper or black mark : 3.1~3.2V Detect paper: 0~0.3V												
3	GND	0V												

# TTP-243 Pro/ 243E Pro/ 342 Pro Bar Code Printer

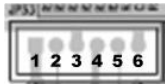

3	Gap sensor connector	JP53																					
		<table border="1"> <thead> <tr> <th>Pin</th> <th>Description</th> <th>Voltage</th> </tr> </thead> <tbody> <tr> <td>1</td> <td>GND</td> <td>0V</td> </tr> <tr> <td>2</td> <td>Gap sensor emitter</td> <td>Emitter on : 0.7~1.8V Emitter off: 2.4~2.7V</td> </tr> <tr> <td>3</td> <td>Power</td> <td>5V</td> </tr> <tr> <td>4</td> <td>GND</td> <td>0V</td> </tr> <tr> <td>5</td> <td>Gap sensor receiver</td> <td>No paper or gap: 3.1~3.2V Detect paper: 0~0.3V</td> </tr> <tr> <td>6</td> <td>Power</td> <td>5V</td> </tr> </tbody> </table>	Pin	Description	Voltage	1	GND	0V	2	Gap sensor emitter	Emitter on : 0.7~1.8V Emitter off: 2.4~2.7V	3	Power	5V	4	GND	0V	5	Gap sensor receiver	No paper or gap: 3.1~3.2V Detect paper: 0~0.3V	6	Power	5V
		Pin	Description	Voltage																			
		1	GND	0V																			
		2	Gap sensor emitter	Emitter on : 0.7~1.8V Emitter off: 2.4~2.7V																			
		3	Power	5V																			
		4	GND	0V																			
5	Gap sensor receiver	No paper or gap: 3.1~3.2V Detect paper: 0~0.3V																					
6	Power	5V																					
4	Ribbon encoder sensor & DC motor connector	JP37																					
5	Stepping motor connector	JP14																					
6	Print head connector	JP49																					
7	SD memory card module connector	JP44																					
8	Micro processor	U2																					
9	Power switch	SW2																					
10	Power supply output (24V DC) connector	B3																					
11	RS-232C connector	JP7																					
12	Centronics port connector (Option)	JP4																					
13	USB connector	JP9																					
14	Push button connector	JP52																					
		<table border="1"> <thead> <tr> <th>Pin</th> <th>Description</th> <th>Voltage</th> </tr> </thead> <tbody> <tr> <td>1</td> <td>LED green (PWR)</td> <td>LED light on: 2.0~2.2V LED light off: 0~0.3V</td> </tr> <tr> <td>2</td> <td>LED green (ONLINE)</td> <td>LED light on: 2.0~2.2V LED light off: 0~0.3V</td> </tr> <tr> <td>3</td> <td>LED red (ERR)</td> <td>LED light on : 2.0~2.2V LED light off: 0~0.3V</td> </tr> <tr> <td>4</td> <td>Pause switch</td> <td>0V: Push key 3.3V: Stand-by</td> </tr> <tr> <td>5</td> <td>Feed switch</td> <td>0V: Push key 3.3V: Stand-by</td> </tr> <tr> <td>6</td> <td>GND</td> <td>0V</td> </tr> </tbody> </table>	Pin	Description	Voltage	1	LED green (PWR)	LED light on: 2.0~2.2V LED light off: 0~0.3V	2	LED green (ONLINE)	LED light on: 2.0~2.2V LED light off: 0~0.3V	3	LED red (ERR)	LED light on : 2.0~2.2V LED light off: 0~0.3V	4	Pause switch	0V: Push key 3.3V: Stand-by	5	Feed switch	0V: Push key 3.3V: Stand-by	6	GND	0V
		Pin	Description	Voltage																			
		1	LED green (PWR)	LED light on: 2.0~2.2V LED light off: 0~0.3V																			
		2	LED green (ONLINE)	LED light on: 2.0~2.2V LED light off: 0~0.3V																			
		3	LED red (ERR)	LED light on : 2.0~2.2V LED light off: 0~0.3V																			
		4	Pause switch	0V: Push key 3.3V: Stand-by																			
5	Feed switch	0V: Push key 3.3V: Stand-by																					
6	GND	0V																					
15	Cutter /peel-off sensor connector (Option for TTP-243/342 Pro, not available for TTP-243E Pro)	JP48																					
16	Head open sensor connector	JP16																					
17	RTC Battery (Not available for TTP-243E Pro)	BT1																					



### 3.2 Pin Configuration

#### RS-232C

PIN	CONFIGURATION
1	+5 V
2	TXD
3	RXD
4	CTS
5	GND
6	RTS
7	N/C
8	RTS
9	N/C

#### USB

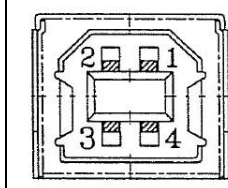

PIN	CONFIGURATION
1	N/C
2	D-
3	D+
4	GND

#### Centronics

Pin	SPP Mode	Nibble	In/Out	Function
1	Strobe	N/A	In	A <b>low</b> on this line indicates that there are valid data at the host. When this pin is de-asserted, the +ve clock edge should be used to shift the data into the device.
2-9	Data 0-7	N/A	In	Data Bus. Single-directional.
10	Ack	N/A	Out	A <b>low</b> on this line indicates that there are valid data at the Device. When this pin is de-asserted, the +ve clock edge should be used to shift the data into the host.
11	Busy	N/A	Out	When in reverse direction, a <b>high</b> indicates data, while a <b>low</b> indicates a command cycle. In forward direction, it functions as PtrBusy.
12	Paper Out / End	N/A	Out	When <b>low</b> , device acknowledges reverse request.
13	Select	N/A	Out	Extensibility flag
14	Ground	N/A	GND	
15	No Defined	N/A	N/A	
16-17	Ground	N/A	GND	Ground
18	No Defined	N/A	N/A	
19-30	Ground	N/A	GND	Ground
31	No Defined	N/A	N/A	
32	Error / Fault	N/A	Out	A <b>low</b> set by the device indicates that the reverse data is available

# TTP-243 Pro/ 243E Pro/ 342 Pro Bar Code Printer



---

33-35	Ground	N/A	GND	Ground
36	No Defined	N/A	N/A	

## **4. MECHANISM**

### **4.1 Mainboard Replacement**

1. Turn off the printer power.
2. Remove the power cord and RS-232 and/or USB cable.
3. Open the top cover of the printer.
4. Remove the printer front panel.

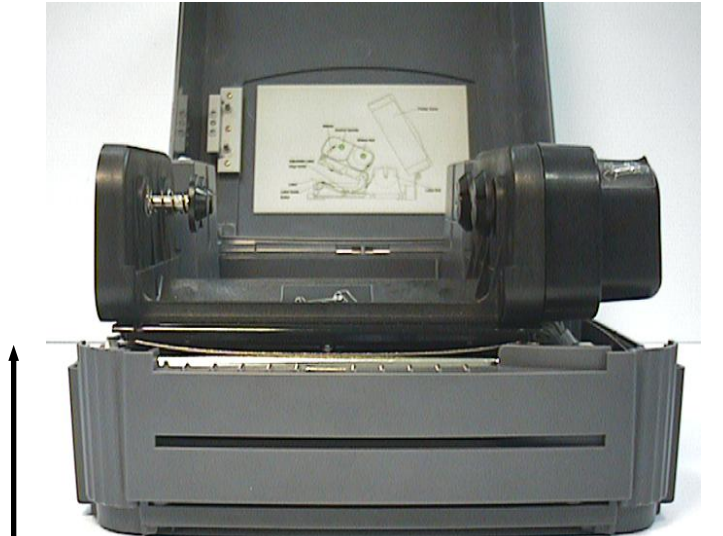

**Remove the front cover  
in the direction of the arrows**

5. Remove the two screws and the metal cover.

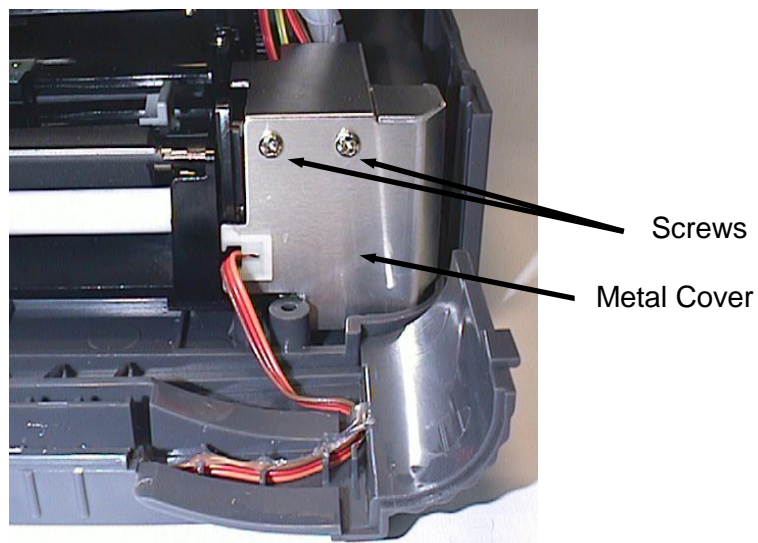

**Remove the screws  
and metal cover**

6. Release the cable tie and remove the peel-off sensor connector. (Not available for TTP-243E Pro model)

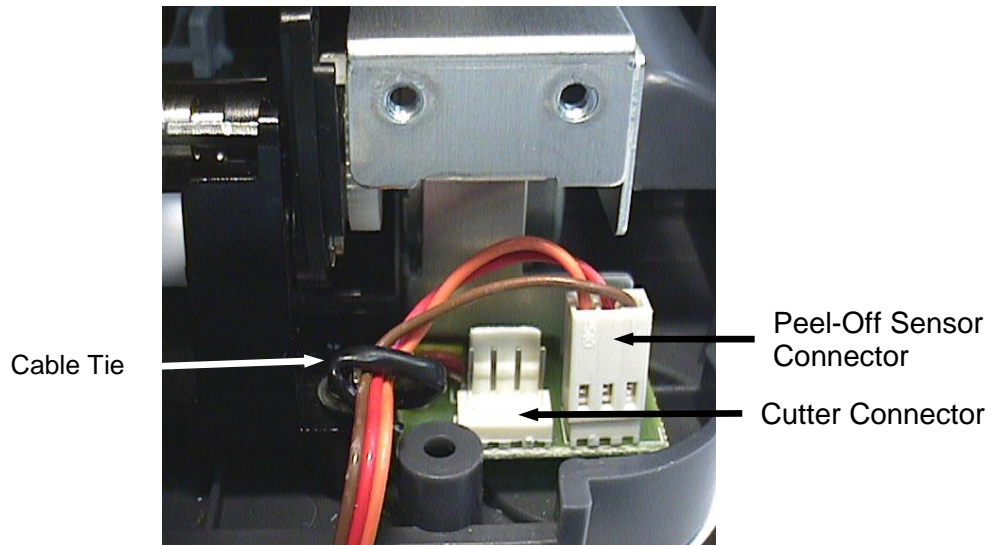

**Cable tie and peel-off sensor connector**

7. Remove the screws on the lower left and lower right corners of main mechanism.

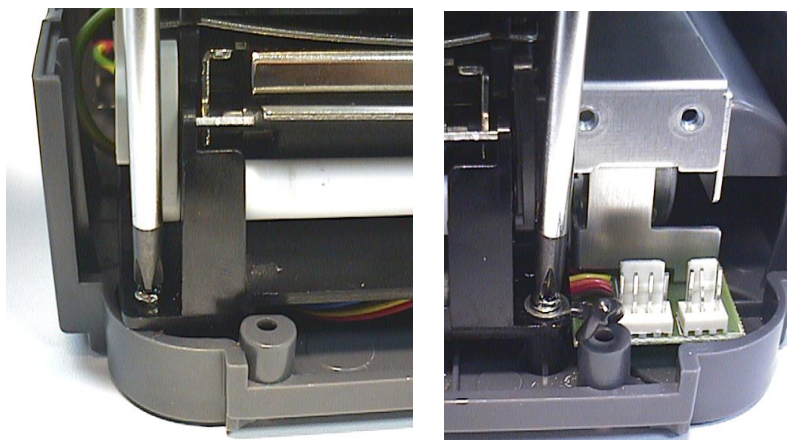

**Remove the screws in the lower left, lower right corners of the main mechanism.**

8. Remove the four screws of the internal label roll mount.

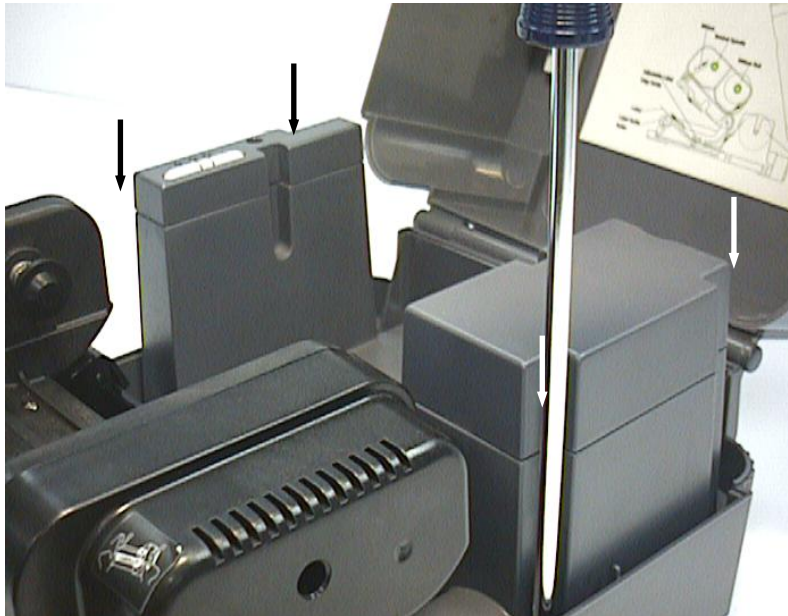

**Fig. 3.18 Remove screws of the label roll mount**

9. Move the mechanism about 5 mm in the label feed direction.

10. Take out the internal label roll mount and remove the connector.

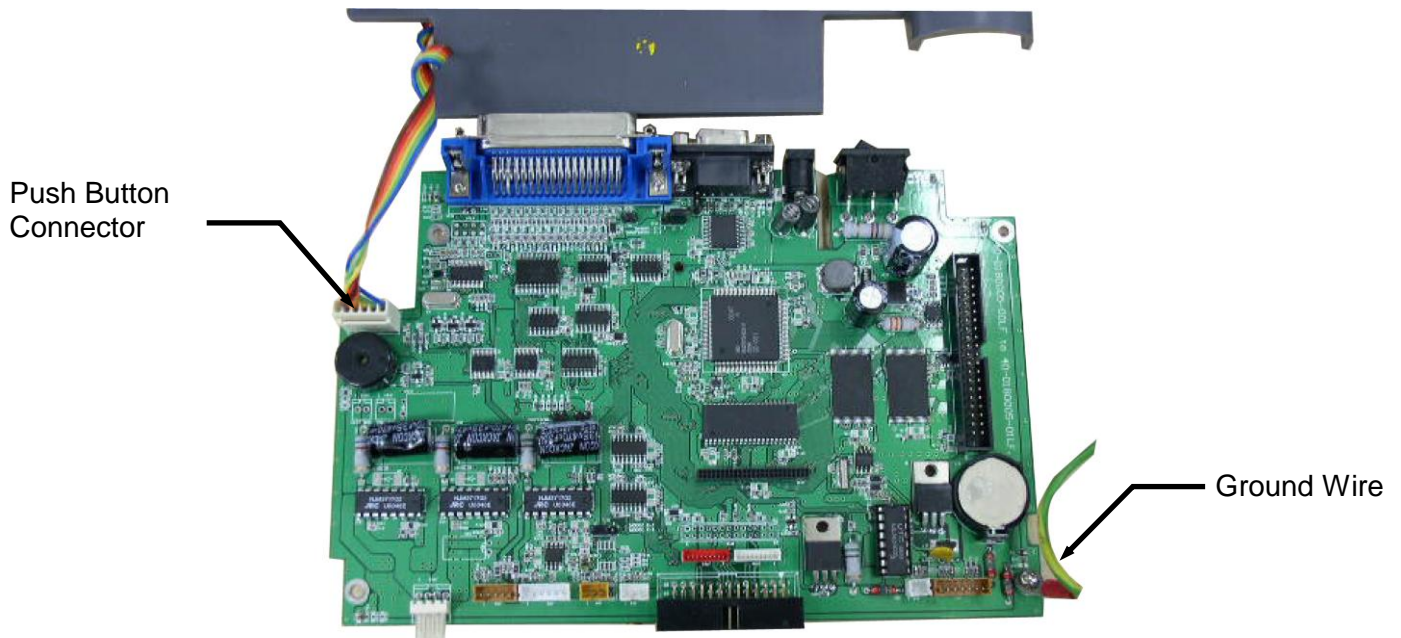

**Take out the internal label roll  
mount and remove the connector**

11. Remove the screw of ground wire on the mainboard.
12. Remove all connectors on the mainboard.
13. Take out the mechanism.
14. Remove the rest three screws on the mainboard.

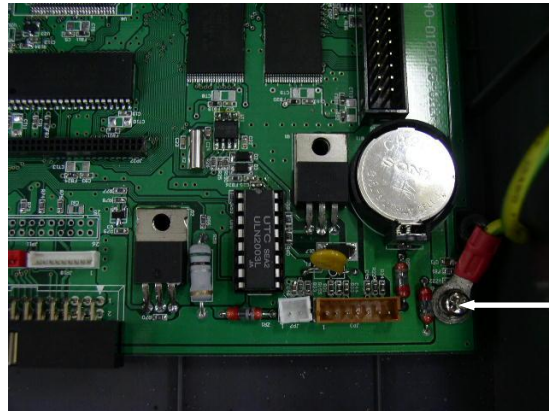
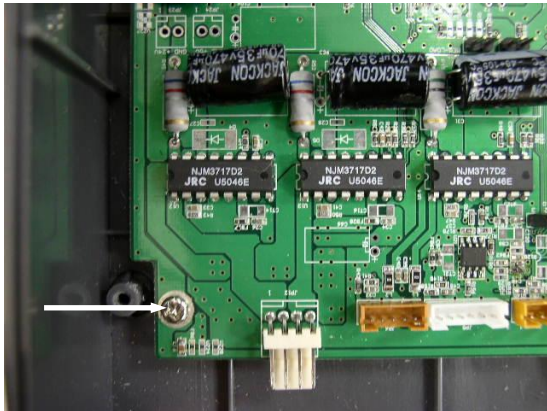
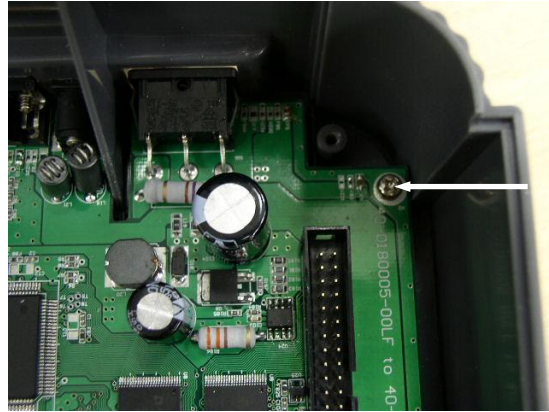

**Upper-Left, Upper-Right, Lower-Right Corner Screw**

15. Replace the mainboard.
16. Reassemble the mechanism and internal label roll mount in the reverse procedures of the removal.

## 4.2 Cutter Installation (Option / Not available for TTP-243E Pro model)

1. Turn off the printer power.
2. Open the top cover of the printer.
3. Remove the printer front panel slowly and carefully. (Cf. 4.1 section)
4. Remove the two screws and the metal cover. (Cf. 4.1 section)
5. Release the cable tie and remove the peel-off sensor connector. (Cf. 4.1 section)
6. Remove the peel-off sensor connector.
7. Plug in the cutter connector.
8. Insert the right and left side flange of cutter into the slot.

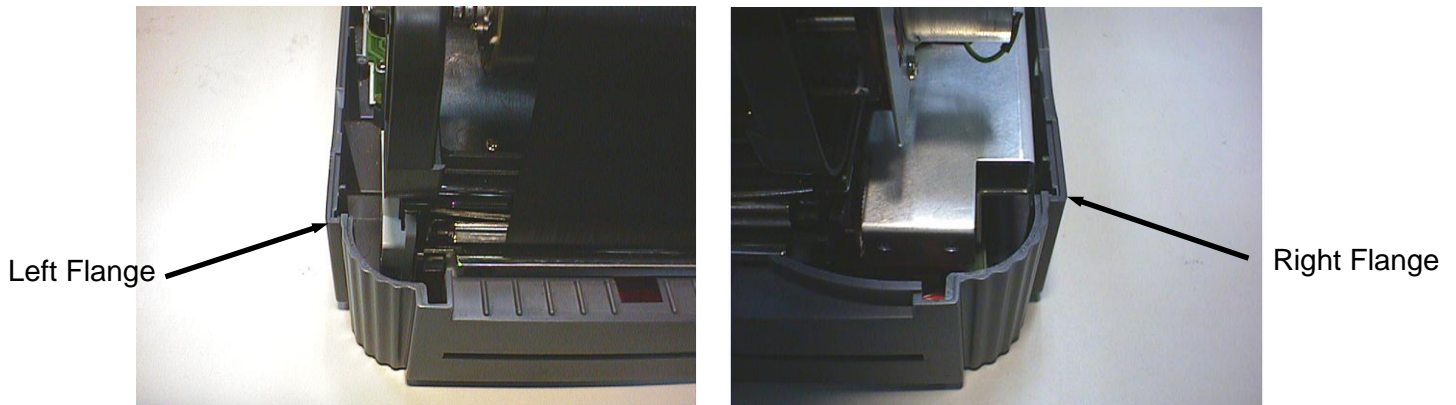

**Cutter Installation**

9. Fasten the cutter from the bottom of the printer with the provided screw.
10. Make sure no screws or other parts are left in the printer.
11. Reassemble the mechanism and internal label roll mount in the reverse procedures of the removal.

## 4.3 Print Head Replacement

1. Turn off the printer power.
2. Remove the RS-232 cable and power cord.
3. Open the top cover.
4. Remove the ribbon and label roll.
5. Open the print carriage.
6. Remove the screw at the top front center of the mechanism, as shown.

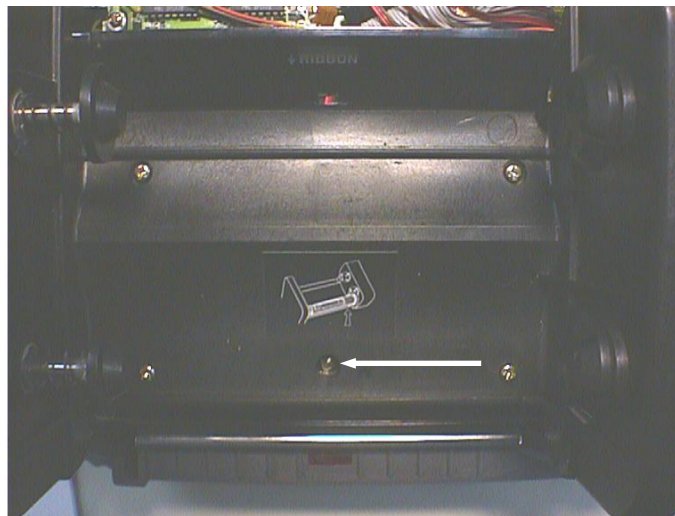

**The Print Head Screw**

7. Disconnect the print head cable.

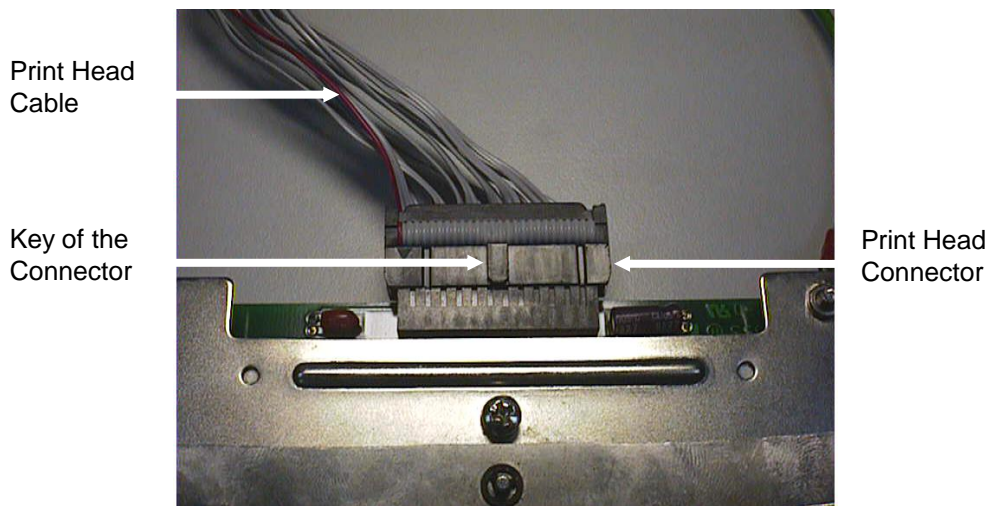

**Printhead and the Cable**



***Note: The key of connector must be positioned upward.  
Do not touch the elements of the print head.  
Do not disassemble the print head.***

8. Tidy up the cable so that it does not protrude or interfere with the ribbon.
9. Reassemble the removed parts in the reverse order of removal.

#### 4.4 DC Motor Replacement

1. Turn off the printer power.
2. Remove the power cord and RS-232 and/or parallel port cable.
3. Open the top cover of the printer.
4. Remove the printer front panel. (Cf. 4.1 section)
5. Remove the two screws and the metal cover. (Cf. 4.1 section)
6. Release the cable tie and remove the peel-off sensor connector. (Cf. 4.1 section)
7. Remove the screw on the PCB of peel-off and cutter connector.
8. Remove the screws in the lower left, lower right corners of the main mechanism. (Cf. 4.1 section)
9. Remove all four screws of the internal label roll mount. (Cf. 4.1 section)
10. Move the mechanism in the label feed direction about 5 mm.
11. Take out the internal label roll mount and remove connector JP52. (Cf. 4.1 section)
12. Remove the screw of ground wire on the mainboard.
13. Remove all connectors on the mainboard.
14. Take out the mechanism.
15. Remove the cable tie.
16. Remove the three screws on DC motor fixture.

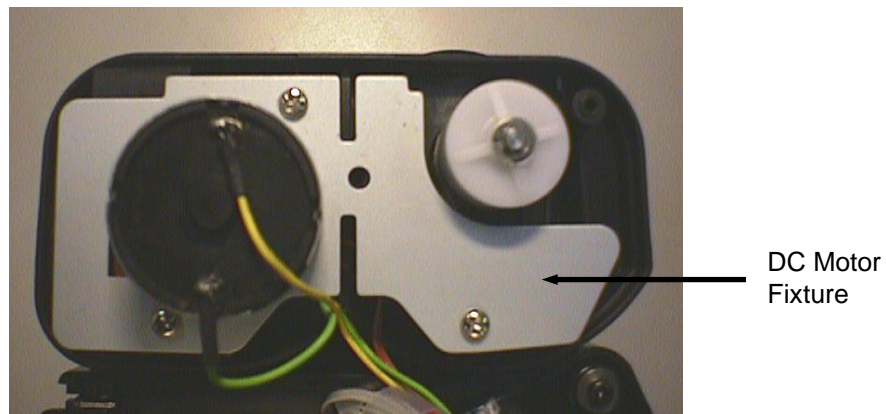

**DC Motor Fixture**

17. Remove the two screws used to fix DC motor on the fixture.
18. Replace the DC motor and pull out the cables in connector JP37.  
**Note: The colors of DC motor wires in connector JP37 are yellow (outside) and green (inside).**
19. Reassemble the removed parts in the reverse order of the removal.

#### **4.5 Ribbon Rewind Spindle Encoder Replacement**

The encoder is installed on the gear box of DC motor, and is used to detect if the ribbon is unerringly rewound by the spindle. The encoder is connected to JP37 on the mainboard. Please switch the printer to thermal transfer mode. The multi-meter is used to measure the voltage of Pin2 (+5V). If the voltage changes continuously from 0 to 5 volts DC, the encoder is in condition. Otherwise, please follow the steps below to replace the encoder PCB

1. Follow directions in Section 4.4 to remove DC motor and DC motor fixture.

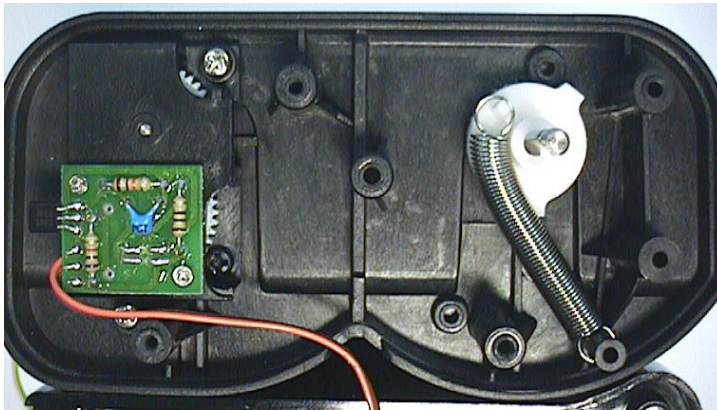

**DC Motor Encoder**

2. Remove the two flat tap screws and cable tie.
3. Replace the Encoder PCB.
4. Reassemble the removed parts in the reverse order of removal.

## 4.6 Felt Fabric Replacement

Felt Fabric is located in the ribbon supply spindle. It is used to tighten the ribbon to prevent it from getting wrinkled during printing. If the ribbon can not be tightened when label back feeds during printing, please replace with a new felt to secure the best printing quality. Follow the steps below to replace the felt fabric.

1. Follow the instructions in Section 4.4 to remove DC motor and DC motor fixture.
2. Remove the E-ring and washer on ribbon supply spindle.

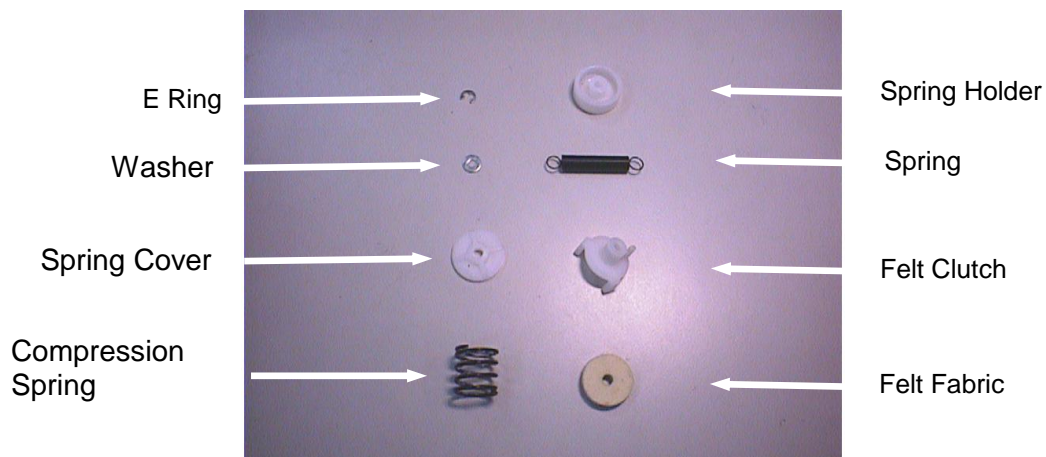

**Components of the  
Ribbon Supply Spindle**

3. Remove the spring cover, compression spring and spring holder.
4. Remove the spring, felt clutch and felt fabric.
5. Replace with a new felt.

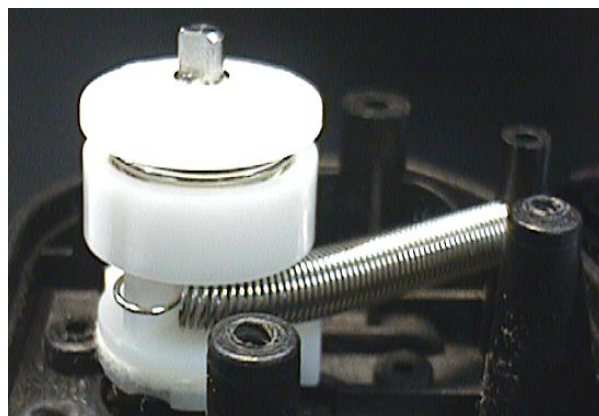

**Side View of the  
Ribbon Supply Spindle Assembly**

6. Reassemble the removed parts in the reverse order of removal.

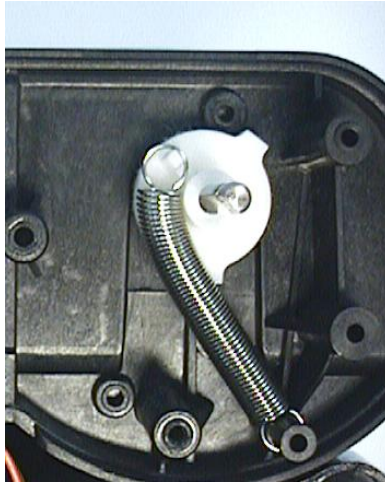

**Front View of the  
Ribbon Supply Spindle**

#### **4.7 Stepping Motor Replacement**

1. Follow the instructions in Section 4.1 to remove all the connectors on mainboard.
2. Take out the mechanism.
3. Remove the two screws of the stepping motor.

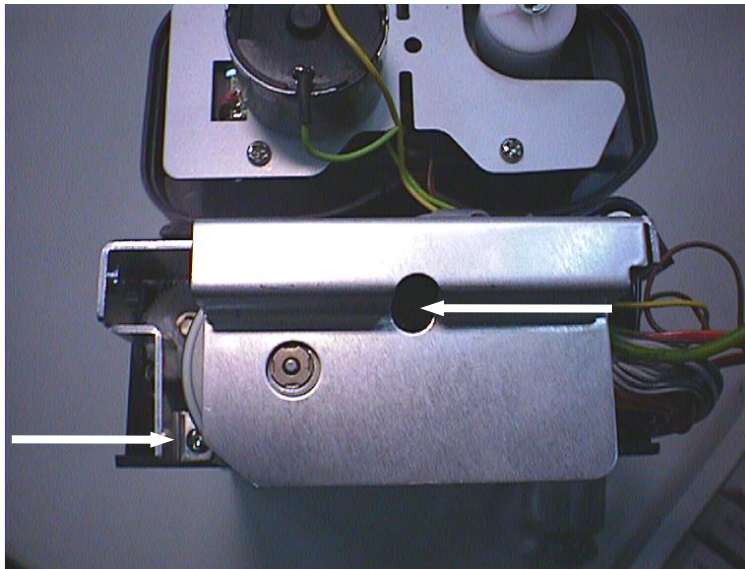

**Stepping Motor**

4. Replace the stepping motor and reassemble the removed parts in the reverse order of removal.

#### **4.8 Black Mark Sensor / Gap Sensor (Receiver) Replacement**

Black mark sensor is reflection type sensor. It is connected to JP46 (3 pin connector). A multi-meter is used to measure the signal of Pin2 to see if there is voltage variation when black mark is detected. Before conducting the test, please issue the BLINE command first. The printer will switch from gap sensor to black mark sensor. If there is no voltage variation, please follow steps below to replace the black mark sensor / gap sensor (receiver) PCB.

1. Follow the instructions in Section 4.1 to remove all the connectors on mainboard.
2. Take out the mechanism.
3. Remove one flat tap screws and black mark sensor PCB.

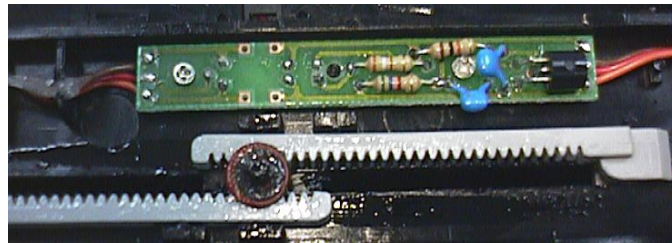

**Black Mark Sensor and Gap Receiver Sensor**

4. Reassemble the removed parts in the reverse order of removal.

#### 4.9 Ribbon Sensor (Receiver) Replacement

1. Follow the instructions in Section 4.1 to remove all the connectors on mainboard.
2. Take out the mechanism.
3. Remove the screws, springs and spring bushing on both sides of the mechanism.

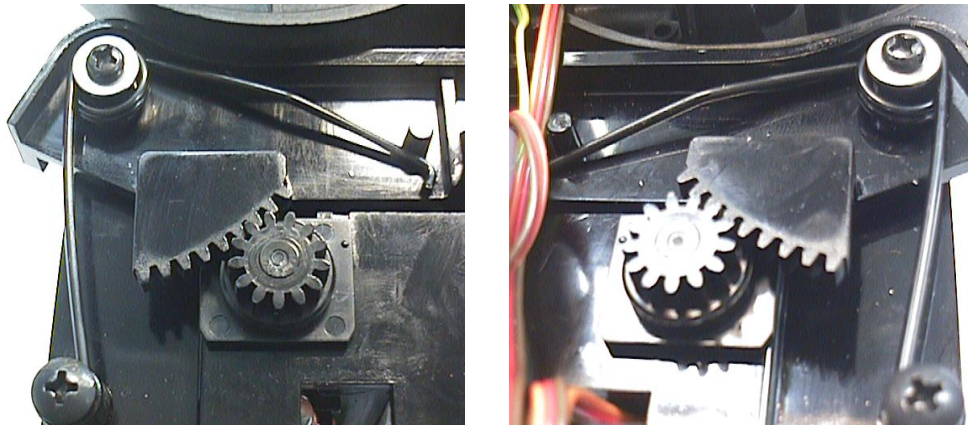

Spring Installation on Left Side and Right Side

**Note:** *The left side spring and the right side spring are different in shape. The right side spring has a straight end, when the left side spring has an end that is curved 90 degrees.*

4. The main mechanism is divided into upper mechanism and lower mechanism.
5. The ribbon sensor (receiver) is located in the upper mechanism.
6. Remove the screws on the ribbon sensor cover.

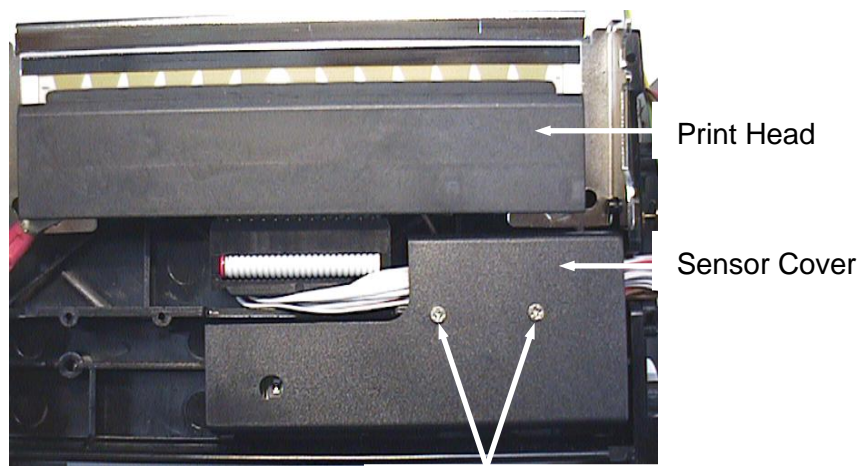

Flat Tap Screw

Ribbon Sensor Cover



7. Replace with a new ribbon sensor PCB.

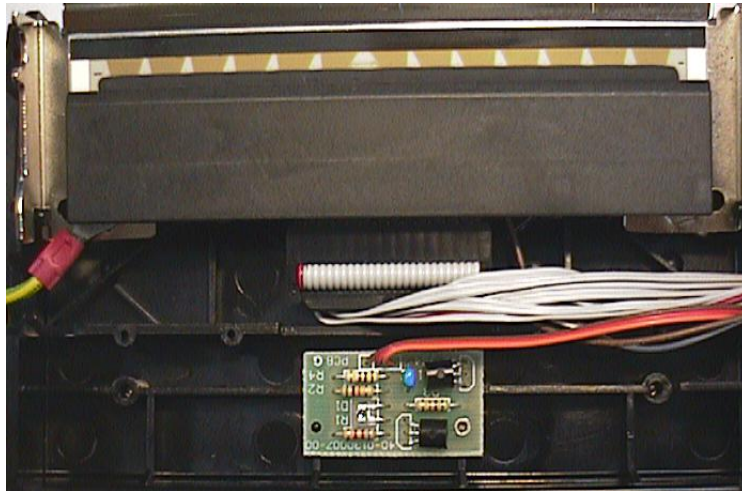

**Ribbon Sensor**

8. Reassemble the removed parts in the reverse order of removal.

## 4.10 Ribbon Sensor (Transmitter) / Gap Sensor (Transmitter) Replacement

1. Follow the instructions in Section 4.1 to remove all the connectors on mainboard.
2. The ribbon sensor (transmitter) is located in the center of the lower mechanism.



**Ribbon Sensor (Transmitter)**

3. Remove the two flat tap screws.
4. Remove the cable tie and sensor PCB.
5. Replace with a new PCB. Reassemble the removed parts in the reverse order of removal.

### 4.11 Platen Replacement

1. Follow the instructions in Section 4.7 to remove the two screws, stepping motor and stepping motor cover.
2. Remove the E ring and two gears.

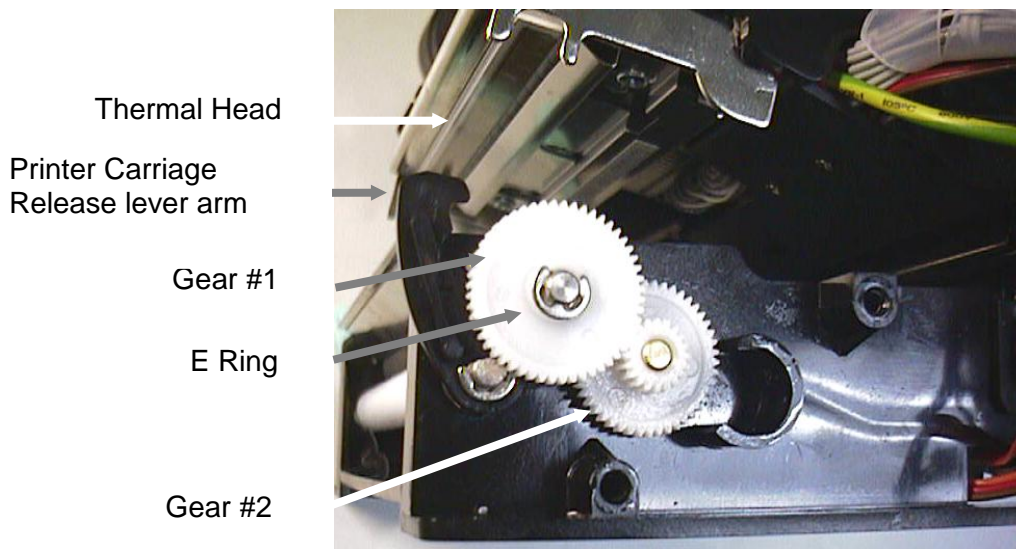

**Location of E ring and Gears**

3. Remove the E-ring and the printer carriage release lever on the left side of the mechanism.
4. Remove the E-ring and the printer carriage release lever arm.

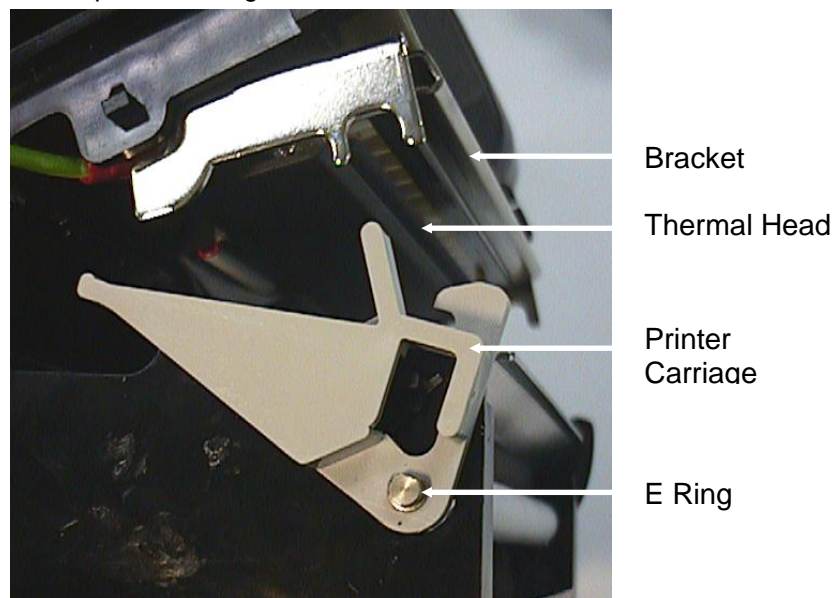

**Printer carriage release lever and E ring**

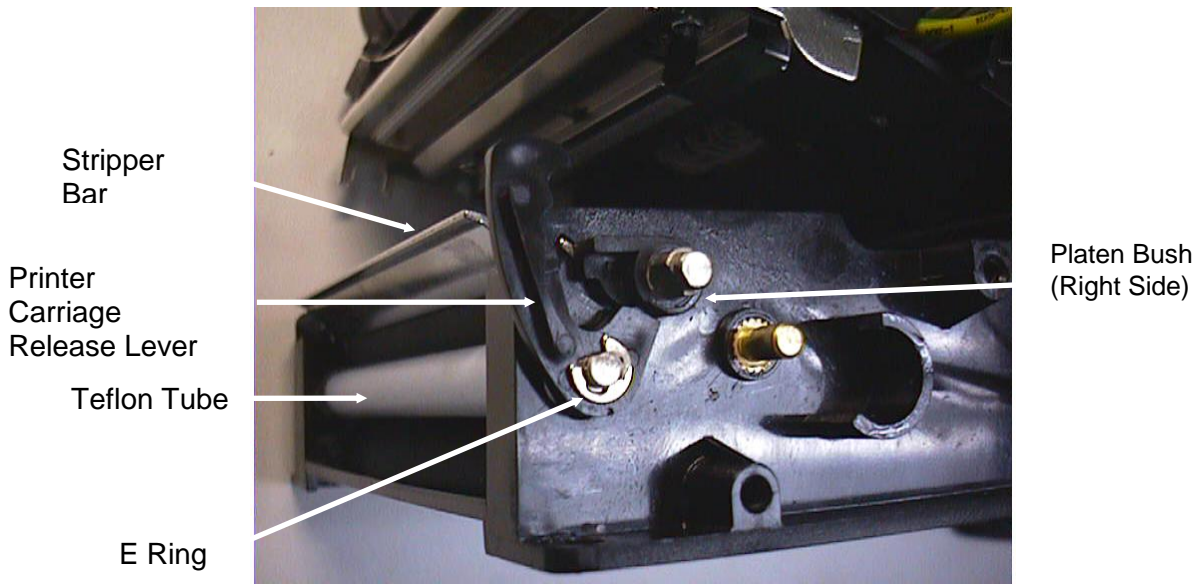

**Printer carriage release lever arm and E ring**

5. Remove the teflon tube and stripper rod.



**Teflon tube and stripper rod**

6. Remove the E ring, the right side and left side platen bushes.

7. Remove the stripper bar.



**Remove E ring and platen bush**

# TTP-243 Pro/ 243E Pro/ 342 Pro Bar Code Printer



- 
8. Move the platen to the right of the mechanism.
  9. Replace the platen and reassemble the removed parts in the reverse order of removal.

## 5. TROUBLE SHOOTING

### 5.1 Trouble Shooting

Problems	Solutions
1. Ribbon does not advance.	Check the printing mode setting and reset the printer.
2. Poor print quality.	Clean the print head. Adjust the print density setting.
3. Only prints diagonal pattern in the self-test.	Ribbon and paper are incompatible. Use a different type of ribbon.
4. Power indicator light does not illuminate.	Check the connection of serial port cable.
5. On-line indicator light does not to illuminate.	Check the DIP switch setting and reset the printer. Check that power cord is properly connected.
6. Error indicator remains illuminated.	Out of paper or out of ribbon.  Check the DIP switch setting  Check the paper core, make sure it is installed on the ribbon rewind spindle.  Press the FEED key. The error message will be printed out on the print media or sent out through RS-232 port.  If there is no problem with direct thermal printing, but error occurs in thermal transfer printing. Please check the encoder of the DC motor.

## **5.2 Calibrate the Gap Register**

Install the label.

Turn on the printer power while pressing the PAUSE button. The printer will calibrate the transparency of the backing paper and adjust the gap register.

## **5.3 Self-test**

Install the label.

Turn on the printer power while pressing the FEED button, the printer will:

- Print head checking pattern.

- Calibrate the label length.

- Print internal settings.

- Initiate self-test.

- Enter dump mode.

## **5.4 Ram Clear**

Press the PAUSE and FEED button simultaneously for more than 3 seconds. The printer will clear the memory and reset the printer.

Be sure to calibrate the gap register with blank label before printing.

## **5.5 Diagnosis Operation Procedure**

When the power is turned on without any button pressed, self diagnosis is performed automatically to test the available memory. If any error occurs during this period, the ERR light will flash.

Do the self test and inspect the test pattern to check if the thermal head is available.

---

## 5.6 Testing Sensors

### A. Checking Ribbon Sensor

Switch the multimeter to the DC gear. Connect the black wire to DC GND, and the red wire to PIN2 of JP18.

1. When ribbon is detected between TX and RX of the ribbon sensor, the measured voltage should be 5 Vdc.
2. When ribbon is not detected between TX and RX of the ribbon sensor, the measured voltage should be 0 Vdc.

The ribbon sensor is normal if the checking complies with the two cases above. Or else, the ribbon sensor is out of order.

### B. Checking DC Motor Encoder Sensor

Switch the multimeter to the DC gear. Connect the black wire to DC GND, and the red wire to PIN4 of U35.

1. When gap of the gear box is detected by the DC motor encoder sensor, the measured voltage should be 5 Vdc.
2. When gap of the gear box is not detected by the DC motor encoder sensor, the measured voltage should be 0 Vdc.

The DC motor encoder sensor is normal if the checking complies with the two cases above. Or else, the DC motor encoder sensor is out of order.

### C. Checking Black Line Sensor

Switch the multimeter to the DC gear. Connect the black wire to DC GND, and the red wire to PIN2 of U2. Load black line label on the printer.

1. When black line is detected by the black line sensor, the measured voltage should be 3 Vdc.
2. When black line is not detected by the black line sensor, the measured voltage should be 0 Vdc.

The black line sensor is normal if the checking complies with the two cases above. Or else, the black line sensor is out of order.



## 5.7 Cleaning the Print Head

The printer should be cleaned regularly to retain high quality and optimum performance. The greater the usage of the printer, the more frequent the cleaning.

Always turn off the printer before cleaning the print head. Allow the printhead to cool for a minimum of one minute.

1. Open the printer cover.
2. Open the printer carriage by pulling up the release lever to the left of the front rubber roller.
3. Remove the ribbon and label.
4. Clean the print head element with a head cleaner pen or use a cotton swab and 100% ethanol to clean the print head surface.

Note:

- \* Do not touch printer head by hand. If you touch it careless, please use ethanol to clean it.
- \* It's industry alcohol. Please do not use regular alcohol, which may damage the printer head.

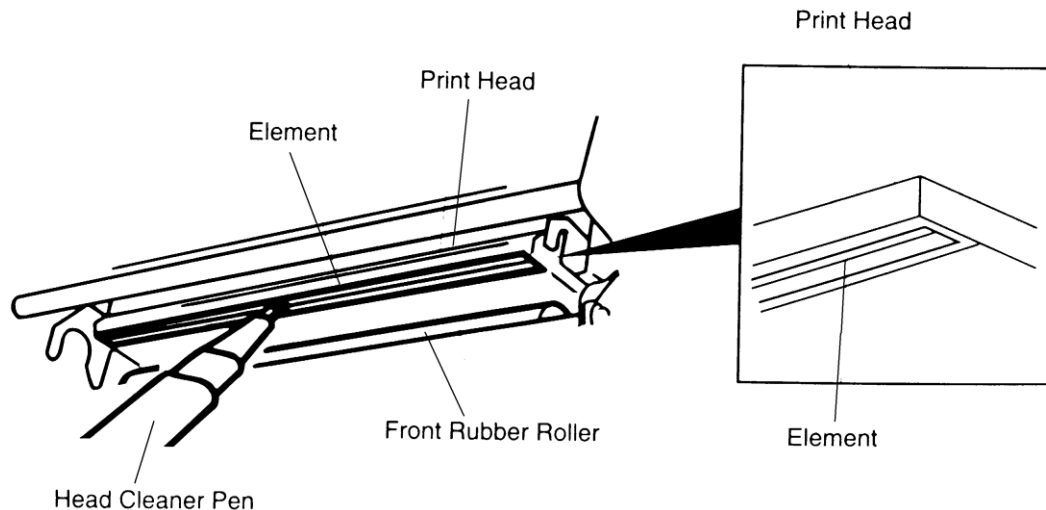

# TTP-243 Pro/ 243E Pro/ 342 Pro Bar Code Printer



---

## Update History

Date	Content	Editor
2011/1/25	Modify TSC address	Camille
2011/4/7	Modify section 3.2	Camille



TSC Auto ID Technology Co., Ltd.

Corporate Headquarters

9F., No.95, Minquan Rd., Xindian Dist.,  
New Taipei City 23141, Taiwan (R.O.C.)

TEL: +886-2-2218-6789

FAX: +886-2-2218-5678

Web site: [www.tscprinters.com](http://www.tscprinters.com)

E-mail: [printer\\_sales@tscprinters.com](mailto:printer_sales@tscprinters.com)

[tech\\_support@tscprinters.com](mailto:tech_support@tscprinters.com)

Li Ze Plant

No.35, Sec. 2, Ligong 1st Rd., Wujie Township,  
Yilan County 26841, Taiwan (R.O.C.)

TEL: +886-3-990-6677

FAX: +886-3-990-5577